

# REEL RETURN INSTALLATION INSTRUCTIONS

Part # 101965 2" Strap – 101966 3" Strap



3400 West O Street  
Lincoln, NE 68528  
402-435-4249  
(Fax) 402-438-3918

[www.thunderstonemfg.com](http://www.thunderstonemfg.com)

March 22<sup>nd</sup> 2019

## PURPOSE

This kit is intended to aid in keeping tension on the rear of the tarp when other standard methods are not possible due to such factors as rear gate doors, end dump or walking floor type trailers.

## BEFORE INSTALLATION

- Determine which way the rear gate doors swing and if they will impact the reel return when opened.
- Determine how far down from the top of the trailer the roll reel can be installed to clear any obstructions. This includes how far the tarp can hang down from the stowed position. Recommended distance is 30"-36" from top rail.

## COMMON INSTALLATION

- Locate the reel return 30-36" down from the top rail on the roadside of the trailer.
- Line up the mounting holes between but in line with the rivets of the corrugated rear panel.
- Mark the mounting hole locations.

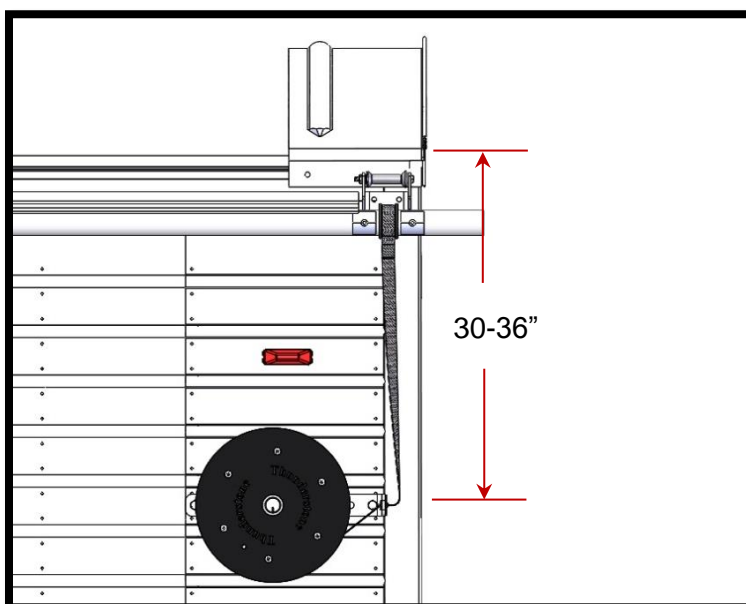

- Drill 17/32" holes through the panel and Z-posts at the marked hole locations.
- Fasten the reel return to the trailer with the supplied 1/2" – 13 X 1 1/2" bolts and nuts.

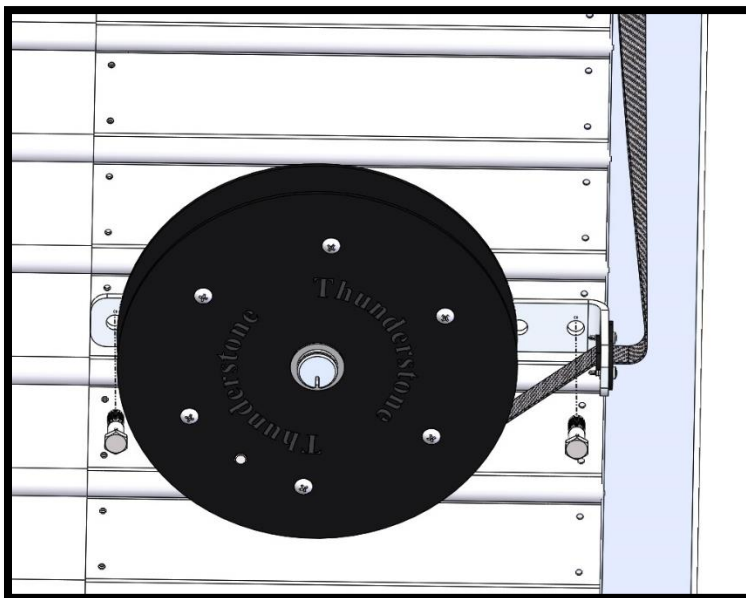

- Locate the standoff bracket 1" down from the bottom of the rear cap on the side pillar.
- Mark the mounting hole locations.
- Drill 5/16" holes through the side pillar at the marked hole locations.
- Fasten the standoff bracket with the supplied 3/8" – 16 X 1" self-threading bolts.

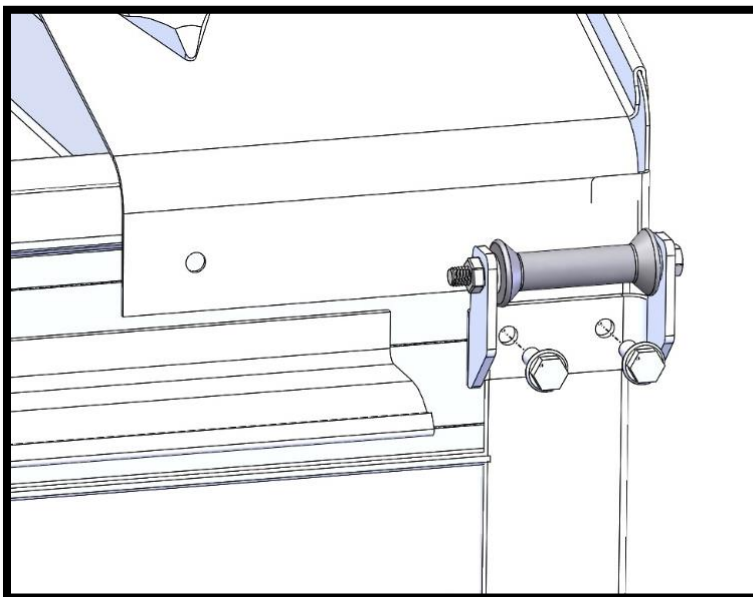

- Slide the reel strap bushing over the end of the tarp roll-tube and center it with the standoff bracket.
- Open and close the tarp across the trailer to check for proper function of the reel return.
- Make sure there is enough strap to make it across the trailer.
- The strap should remain centered with the standoff bracket throughout the tarping cycle.
- Once proper operation is verified, install the bushing retainer clips to either side of the reel strap bushing using the supplied #14 X 3/4" self-tapping screws.

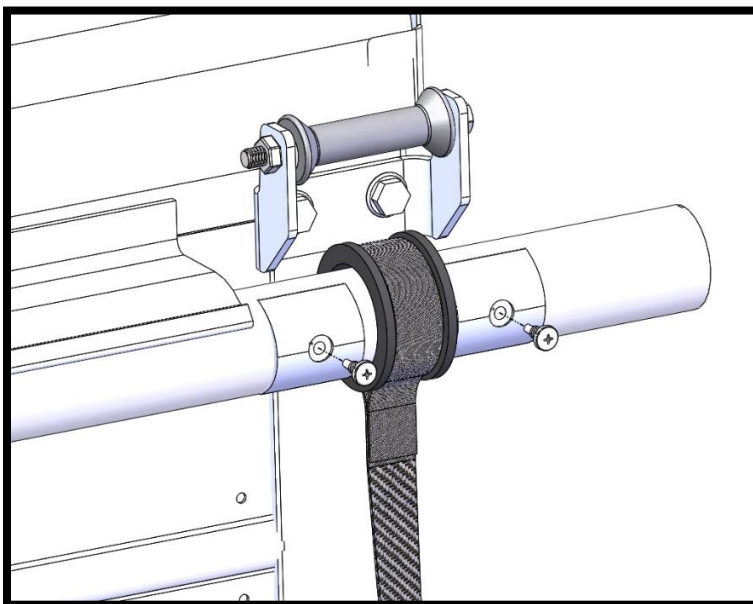

## COMMON INSTALLATION COMPLETED



Other forms of mounting may be necessary depending on trailer type, door locations, etc. Always keep in mind the limit of how much strap can be unwound, the more strap that is unwound the more tension will be produced.



**CAUTION: DO NOT REMOVE THE BOLTS THAT HOLD THE TWO HALVES OF THE UNIT TOGETHER AS THIS CAN RESULT IN INJURY. COMPONENTS UNDER SPRING TENSION.**